

转弯机链条 Turning Machine Chain

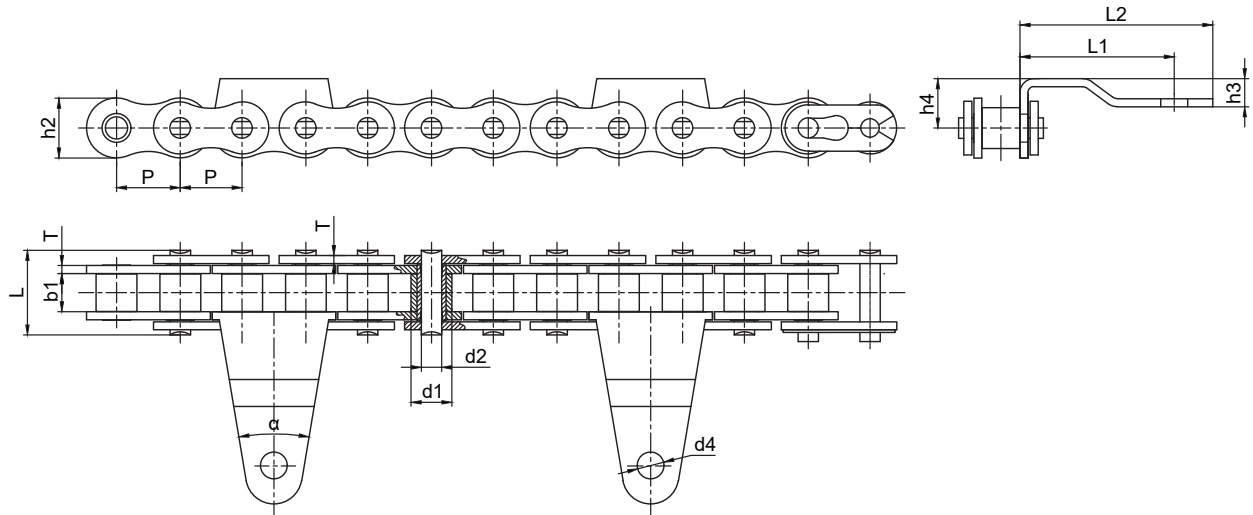

征和链号 CHOHO Chain No.	节距	滚子直径	内节内宽	销轴直径	销轴长度	链板尺寸		附板尺寸					转弯半径	抗拉强度	平均抗拉强度	
	Pitch	Roller diameter	Width between inner plates	Pin diameter	Pin length	Plate dimensions		Attachment dimensions					Turning radius	Ultimate tensile strength	Average Tensile Strength	
	P	d1 max	b1 min	d2 max	L max	h2 max	T max	h3	h4	L1	L2	α	d4	R min	Q min	Q ₀
	mm	mm	mm	mm	mm	mm	mm	mm	mm	mm	mm	°	mm	mm	kN	kN
50F9	15.875	10.16	9.50	5.08	21.1	15.05	2.00	7.00	12.30	38.40	48.20	19.00	5.20	1500.00	26.5	29.3
50SBF1	15.875	10.16	9.50	5.08	21.1	14.90	2.00	7.00	12.30	38.40	48.20	19.00	6.70	330.00	20.6	22.7
50SBV2	15.875	10.16	9.50	5.08	21.1	14.90	2.00	7.00	12.50	45.00	54.00	3.00	5.00	330.00	20.6	22.7
50SBV3	15.875	10.16	9.50	5.08	21.1	14.90	2.00	7.00	12.30	51.30	60.90	15.00	5.00	330.00	20.6	22.7
50SBV4	15.875	10.16	9.50	5.08	21.1	15.05	2.00	7.00	12.30	43.15	52.75	19.00	6.20	1500.00	26.5	29.3

输送链
Conveyor Chains

曳引链
Leaf Chains

传动链
Driving Chains

键槽和螺纹
Keyway And Thread

A系列滚子链轮
Sprocket - A Series

B系列滚子链轮
Sprocket - B Series

双节距链轮
Double Pitch Sprocket

双驱链轮
Double-Drive Sprocket

同步带轮
Synchronous Pulley

侧弯链条 Side Bow Chains

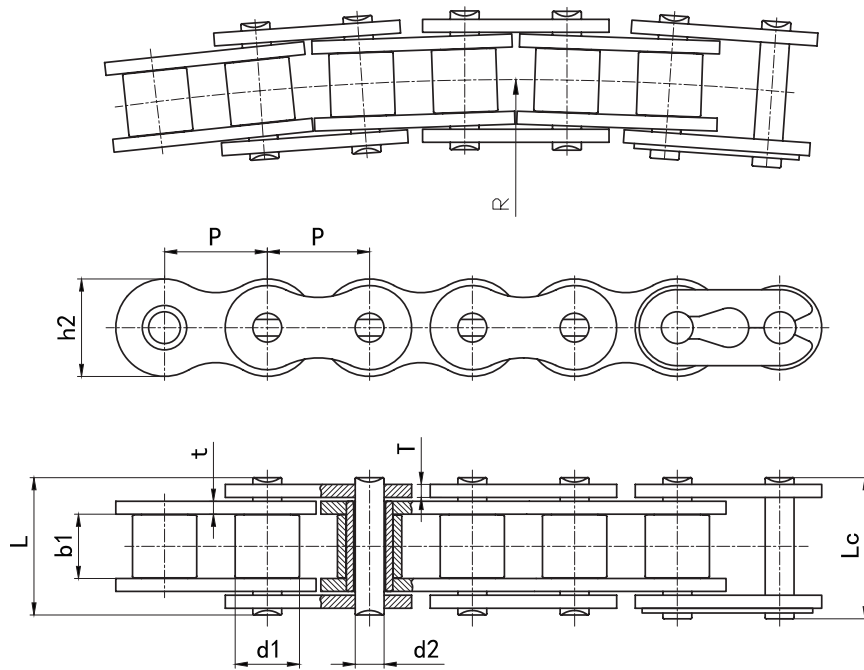

征和链号 CHOHO Chain No.	节距	滚子直径	内节内宽	销轴直径	销轴长度		内链板高度	链板厚度	侧弯半径	抗拉强度	平均抗拉强度	每米重量
	Pitch	Roller diameter	Width between inner plates	Pin diameter	Pin length		Inner plate depth	Plate thickness	Side bow radius	Ultimate Tensile Strength	Average Tensile Strength	Weight per meter
	P	d1 max	b1 min	d2 max	L max	Lc max	h2 max	t/T max	R min	Q min	Q ₀	q
	mm	mm	mm	mm	mm	mm	mm	mm	mm	kN	kN	kg/m
40SB	12.700	7.92	7.85	3.96	16.9	18.1	11.70	1.50	350.0	13.8	15.2	0.80
50SB	15.875	10.16	9.40	4.37	20.7	22.7	14.90	2.00	400.0	20.6	22.7	1.09
60SB	19.050	11.91	12.57	5.34	26.6	28.4	18.00	2.42	500.0	29.0	31.0	1.54
80SB	25.400	15.88	15.75	7.19	34.0	37.3	24.00	3.20	711.0	40.9	42.0	2.60
08BSB	12.700	8.51	7.75	3.97	17.4	18.7	11.80	1.60	400.0	14.0	15.4	0.70
10BSB	15.875	10.16	9.65	4.50	20.1	21.5	14.70	1.70	400.0	15.6	17.2	0.93
12BSB	19.050	12.07	11.68	5.12	23.1	24.8	16.00	1.85	500.0	20.5	22.6	1.16
16BSB	25.400	15.88	17.02	7.90	36.5	39.7	21.00	3.7/3.0	500.0	55.6	64.0	2.53

输送机
Conveyor Chains

曳引链
Leaf Chains

传动链
Driving Chains

键槽和螺纹
Keyway And Thread

A系列滚子链轮
Sprocket - A Series

B系列滚子链轮
Sprocket - B Series

双节距链轮
Double Pitch Sprocket

双驱动链轮
Double-Drive Sprocket

同步带轮
Synchronous Pulley