

ISO 1275 208A ANSI 2040/C2040

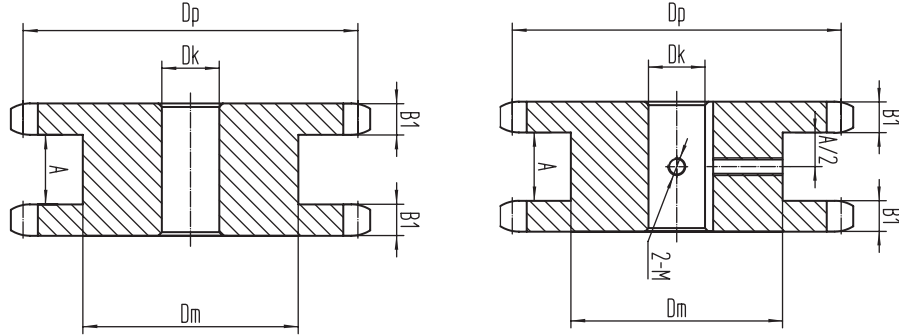

链号 sprocket Type	齿数 teeth number	节圆径 Pitch diameter	齿顶圆 addendum circle	孔径 bore diameter		总厚度 aggregate thickness	排距 array pitch	凸缘 flange	齿厚
				Min	Max				
06B	14	42.80	46.9	10	20	23.5	18.17	31	5.31
	15	45.81	50.0	10	23	23.5	18.17	34	5.31
	16	48.82	53.0	10	25	23.5	18.17	37	5.31
	17	51.84	56.1	10	27	23.5	18.17	40	5.31
	18	54.85	59.2	10	29	23.5	18.17	43	5.31
	19	57.87	62.2	10	31	23.5	18.17	46	5.31
	20	60.89	65.3	10	33	23.5	18.17	48	5.31
	21	63.91	68.3	10	35	23.5	18.17	52	5.31
	22	66.93	71.4	12	36	23.5	18.17	55	5.31
	23	69.95	74.4	12	38	23.5	18.17	58	5.31
	24	72.97	77.5	12	40	23.5	18.17	61	5.31
25	76.00	80.5	12	43	23.5	18.17	64	5.31	
08B	12	49.07	54.3	12	24	35.7	28.58	35	7.2
	13	53.07	58.4	12	26	35.7	28.58	38	8.2
	14	57.07	62.5	12	27	35.7	28.58	41	9.2
	15	61.08	66.6	12	30	35.7	28.58	46	10.2
	16	65.10	70.7	12	34	35.7	28.58	50	11.2
	17	69.12	74.8	12	36	35.7	28.58	54	12.2
	18	73.14	78.9	12	38	35.7	28.58	58	13.2
	19	77.16	83.0	12	41	35.7	28.58	63	14.2
	20	81.18	87.0	12	44	35.7	28.58	66	15.2
	21	85.21	91.1	16	46	35.7	28.58	70	16.2
	22	89.24	95.2	16	48	35.7	28.58	74	17.2
23	93.27	99.3	16	52	35.7	28.58	78	18.2	
24	97.30	103.3	16	54	35.7	28.58	82	19.2	
25	101.33	107.4	16	57	35.7	28.58	86	20.2	

输送机
Conveyor Chains

曳引链
Leaf Chains

传动链
Driving Chains

键槽和螺纹
Keyway And Thread

A系列滚子链轮
Sprocket - A Series

B系列滚子链轮
Sprocket - B Series

双节距链轮
Double Pitch Sprocket

双驱链轮
Double-Drive Sprocket

同步带轮
Synchronous Pulley

双驱链轮 Double Drive Sprocket

输送带
Conveyor Chains

曳引链
Leaf Chains

传动链
Driving Chains

键槽和螺纹
Keyway And Thread

A系列滚子链轮
Sprocket - A-Series

B系列滚子链轮
Sprocket - B-Series

双节距链轮
Double Pitch Sprocket

双驱链轮
Double-Drive Sprocket

同步带轮
Synchronous Pulley

链号	齿数	节圆径	齿顶圆	孔径		总厚度	排距	凸缘	齿厚
	Z	Dp	Da	Min	Max	L	A	Dk	B1
10B	12	61.36	67.8	16	30	42	33.34	43	9.1
	13	66.36	73.0	16	34	42	33.34	48	9.1
	14	71.36	78.2	16	36	42	33.34	53	9.1
	15	76.38	83.3	16	40	42	33.34	58	9.1
	16	81.40	88.4	16	42	42	33.34	64	9.1
	17	86.42	93.5	16	44	42	33.34	68	9.1
	18	91.45	98.6	16	47	42	33.34	73	9.1
	19	96.48	103.7	16	52	42	33.34	78	9.1
	20	101.51	108.8	16	57	42	33.34	83	9.1
	21	106.55	113.9	16	57	42	33.34	88	9.1
	22	111.58	119.0	16	61	42	33.34	93	9.1
	23	116.62	124.1	16	65	42	33.34	98	9.1
	24	121.66	129.2	16	69	42	33.34	103	9.1
25	126.70	134.3	16	72	42	33.34	110	9.1	
12B	12	73.60	81.4	19	35	49.2	38.1	53	11.1
	13	79.60	87.6	19	38	49.2	38.1	59	11.1
	14	85.61	93.8	19	42	49.2	38.1	65	11.1
	15	91.63	99.9	19	38	49.2	38.1	72	11.1
	16	97.65	106.1	19	46	49.2	38.1	77	11.1
	17	103.67	112.2	19	55	49.2	38.1	82	11.1
	18	109.70	118.3	19	58	49.2	38.1	88	11.1
	19	115.74	124.4	19	62	49.2	38.1	94	11.1
	20	121.78	130.6	19	65	49.2	38.1	100	11.1
	21	127.82	136.7	24	70	49.2	38.1	106	11.1
	22	133.86	142.8	24	73	49.2	38.1	112	11.1
	23	139.90	148.9	24	77	49.2	38.1	118	11.1
	24	145.95	155.0	24	81	49.2	38.1	124	11.1
25	151.99	161.1	24	85	49.2	38.1	130	11.1	

链号	齿数	节圆径	齿顶圆	孔径		总厚度	排距	凸缘	齿厚
	Z	Dp	Da	Min	Max	L	A	Dk	B1
16B	12	98.14	108.5	25	46	63.5	46.5	72	16.2
	13	106.14	116.8	25	50	63.5	46.5	80	16.2
	14	114.15	125.0	25	57	63.5	46.5	88	16.2
	15	122.17	133.2	25	60	63.5	46.5	96	16.2
	16	130.20	141.4	25	68	63.5	46.5	104	16.2
	17	138.23	149.6	25	71	63.5	46.5	112	16.2
	18	146.27	157.8	25	79	63.5	46.5	120	16.2
	19	154.32	165.9	25	82	63.5	46.5	128	16.2
	20	162.37	174.1	25	88	63.5	46.5	135	16.2
	21	170.42	182.2	25	95	63.5	46.5	142	16.2
	22	178.48	190.4	25	100	63.5	46.5	151	16.2
	23	186.54	198.5	25	107	63.5	46.5	160	16.2
	24	194.60	206.6	25	111	63.5	46.5	167	16.2
25	202.66	214.8	25	115	63.5	46.5	175	16.2	
20B	13	132.67	146.0	25	63.50	68.3	49.8	96	18.5
	14	142.68	156.3	25	69.85	68.3	49.8	106	18.5
	15	152.71	166.5	32	77.80	68.3	49.8	116	18.5
	16	162.75	176.8	32	82.55	68.3	49.8	114	18.5
	17	172.79	187.0	32	92.10	68.3	49.8	124	18.5
	18	182.84	197.2	32	95.25	68.3	49.8	134	18.5
	19	192.90	207.4	32	106.36	68.3	49.8	157	18.5
	20	202.96	217.6	32	106.36	68.3	49.8	167	18.5
	21	213.03	227.8	32	106.36	68.3	49.8	177	18.5
	23	93.27	99.3	16	52	35.7	28.58	78	18.2
24	97.30	103.3	16	54	35.7	28.58	82	19.2	
25	101.33	107.4	16	57	35.7	28.58	86	20.2	

输送机
Conveyor Chains

曳引链
Leaf Chains

传动链
Driving Chains

键槽和螺纹
Keyway And Thread

A系列滚子链轮
Sprocket - A Series

B系列滚子链轮
Sprocket - B Series

双节距链轮
Double Pitch Sprocket

双驱链轮
Double-Drive Sprocket

同步带轮
Synchronous Pulley