

# A系列直板输送链条 Straight Side Plate Conveyor Chains (A Series)

## ■ 单排、双排、三排 Simplex / Duplex / Triplex

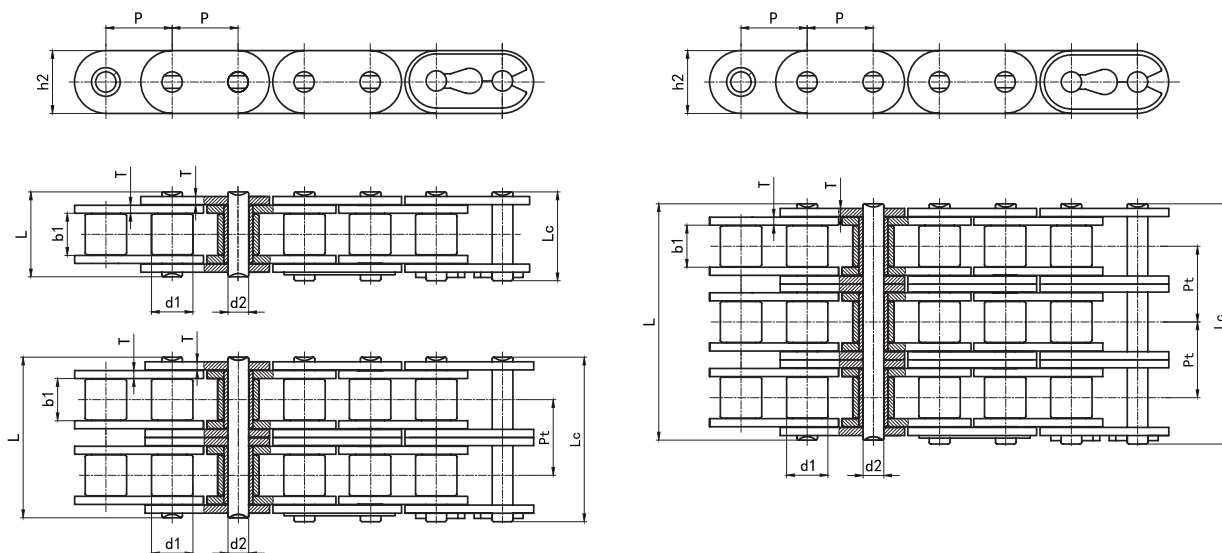

DIN 链号	ISO/ANSI 链号	节距	滚子直径	内节内宽	销轴直径	销轴长度		内链板高度	链板厚度	排距	抗拉强度	平均抗拉强度	每米重量
		Pitch	Roller diameter	Width between inner plates	Pin diameter	Pin length	L max	Lc max	Inner plate depth	Plate thickness	Transverse pitch	Ultimate tensile strength	Average tensile strength
DIN Chain No.	ISO/ANSI Chain No.	p	d1 max	b1 min	d2 max	L max	Lc max	h2 max	T max	Pt	Q min	Q <sub>0</sub>	q
		mm	mm	mm	mm	mm	mm	mm	mm	mm	kN	kN	kg/m
C08A-1	C40-1	12.700	7.92	7.85	3.98	16.7	18.3	12.07	1.50	/	13.9	18.0	0.78
C10A-1	C50-1	15.875	10.16	9.40	5.09	20.7	23.8	15.09	2.00	/	21.8	29.8	1.27
C12A-1	C60-1	19.050	11.91	12.57	5.96	26.2	28.3	18.10	2.42	/	31.3	42.5	1.81
C16A-1	C80-1	25.400	15.88	15.75	7.94	32.9	36.4	24.13	3.20	/	55.6	73.5	3.03
C20A-1	C100-1	31.750	19.05	18.90	9.54	40.8	44.1	30.17	4.00	/	87.0	111.0	4.51
C24A-1	C120-1	38.100	22.23	25.22	11.11	50.8	54.7	36.20	4.80	/	125.0	158.0	6.63
C28A-1	C140-1	44.450	25.40	25.22	12.71	54.7	61.0	42.23	5.60	/	170.0	213.2	8.52
C32A-1	C160-1	50.800	28.58	31.55	14.29	65.5	70.0	48.26	6.40	/	223.0	280.0	11.48
C08A-2	C40-2	12.700	7.92	7.85	3.98	31.2	33.3	12.07	1.50	14.38	27.8	36.0	1.43
C10A-2	C50-2	15.875	10.16	9.40	5.09	39.1	40.6	15.09	2.00	18.11	43.6	58.5	2.42
C12A-2	C60-2	19.050	11.91	12.57	5.96	49.1	50.8	18.10	2.42	22.78	62.6	83.5	3.58
C16A-2	C80-2	25.400	15.88	15.75	7.94	62.1	65.5	24.13	3.20	29.29	111.2	143.0	6.15
C20A-2	C100-2	31.750	19.05	18.90	9.54	76.6	80.5	30.17	4.00	35.76	174.0	221.0	9.08
C24A-2	C120-2	38.100	22.23	25.22	11.11	96.3	100.2	36.20	4.80	45.44	250.0	315.5	13.62
C28A-2	C140-2	44.450	25.40	25.22	12.71	103.6	110.1	42.23	5.60	48.87	340.0	429.0	16.85
C32A-2	C160-2	50.800	28.58	31.55	14.29	124.1	128.6	48.26	6.40	58.55	446.0	563.0	22.90
C08A-3	C40-3	12.700	7.92	7.85	3.98	45.5	47.1	12.07	1.50	14.38	41.7	50.8	2.14
C10A-3	C50-3	15.875	10.16	9.40	5.09	56.9	58.3	15.09	2.00	18.11	65.4	78.0	3.62
C12A-3	C60-3	19.050	11.91	12.57	5.96	71.8	73.6	18.10	2.42	22.78	93.9	113.0	5.36
C16A-3	C80-3	25.400	15.88	15.75	7.94	91.8	95.1	24.13	3.20	29.29	166.8	200.0	9.10
C20A-3	C100-3	31.750	19.05	18.90	9.54	112.1	116.7	30.17	4.00	35.76	261.0	311.0	13.60
C24A-3	C120-3	38.100	22.23	25.22	11.11	141.3	145.2	36.20	4.80	45.44	375.0	440.0	20.43
C28A-3	C140-3	44.450	25.40	25.22	12.71	152.0	157.9	42.23	5.60	48.87	510.0	598.0	25.23
C32A-3	C160-3	50.800	28.58	31.55	14.29	181.8	186.3	48.26	6.40	58.55	669.0	784.0	34.19

输送带  
Conveyor Chains

曳引链  
Leaf Chains

传动链  
Driving Chains

键槽和螺纹  
Keyway And Thread

A系列滚子链轮  
Sprocket - A-Series

B系列滚子链轮  
Sprocket - B-Series

双节距链轮  
Double Pitch Sprocket

双驱动链轮  
Double-Drive Sprocket

同步带轮  
Synchronous Pulley

# B 系列直板输送链条 Straight Side Plate Conveyor Chains (B Series)

## ■ 单排、双排、三排 Simplex / Duplex / Triplex

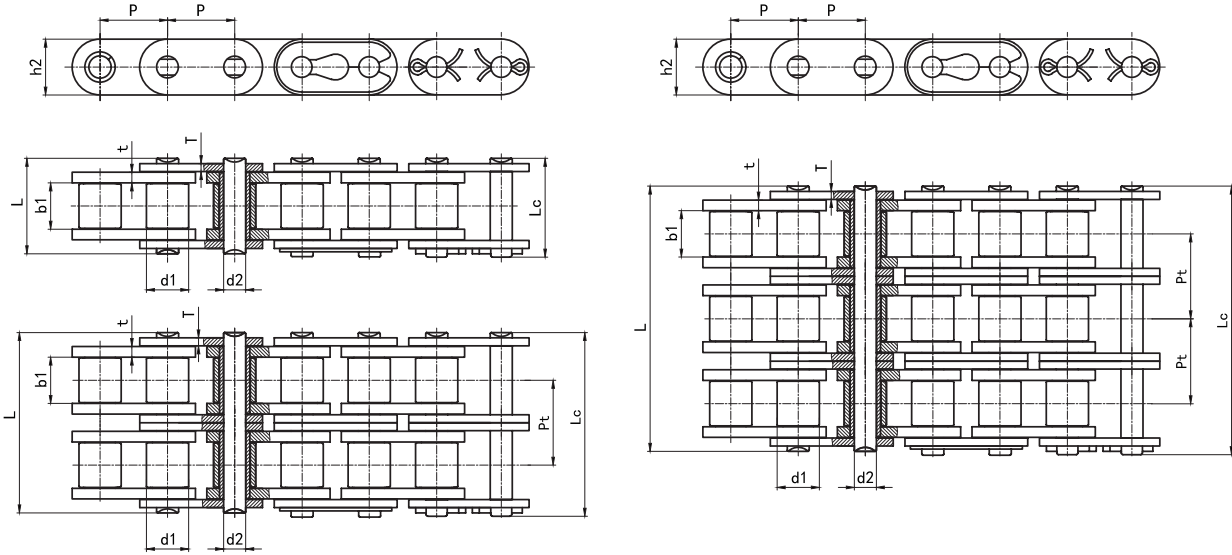

ISO/DIN 链号	节距	滚子直径	内节内宽	销轴直径	销轴长度		内链板高度	链板厚度	排距	抗拉强度	平均抗拉强度	每米重量
	Pitch	Roller diameter	Width between inner plates	Pin diameter	Pin length		Inner plate depth	Plate thickness	Transverse pitch	Ultimate tensile strength	Average tensile strength	Weight per meter
ISO/DIN Chain No.	P	d1 max	b1 min	d2 max	L max	Lc max	h2 max	t/T max	Pt	Q min	Q <sub>0</sub>	q
	mm	mm	mm	mm	mm	mm	mm	mm	mm	kN	kN	kg/m
C08B-1	12.700	8.51	7.75	4.45	17.0	19.2	11.81	1.60	/	17.8	20.0	0.80
C10B-1	15.875	10.16	9.65	5.08	19.6	22.3	14.73	1.70	/	22.2	28.0	1.06
C12B-1	19.050	12.07	11.68	5.72	22.6	25.0	16.13	1.85	/	28.9	33.0	1.32
C16B-1	25.400	15.88	17.02	8.28	36.1	39.2	21.08	4.0/3.0	/	60.0	73.5	3.08
C20B-1	31.750	19.05	19.56	10.19	41.4	46.5	26.42	4.5/3.5	/	95.0	107.0	4.16
C24B-1	38.100	25.40	25.40	14.63	53.4	59.9	33.40	6.0/4.8	/	160.0	180.0	7.47
C28B-1	44.450	27.94	30.99	15.90	65.1	71.5	37.08	7.5/6.0	/	200.0	221.0	9.90
C32B-1	50.800	29.21	30.99	17.81	66.8	72.5	42.29	7.0/6.0	/	250.0	279.0	10.45
C08B-2	12.700	8.51	7.75	4.45	31.0	32.7	11.81	1.60	13.92	31.1	39.0	1.45
C10B-2	15.875	10.16	9.65	5.08	36.2	38.3	14.73	1.70	16.59	44.5	56.0	2.00
C12B-2	19.050	12.07	11.68	5.72	42.0	44.4	16.13	1.85	19.46	57.8	67.0	2.62
C16B-2	25.400	15.88	17.02	8.28	68.0	71.2	21.08	4.0/3.0	31.88	106.0	134.0	6.10
C20B-2	31.750	19.05	19.56	10.19	77.9	83.0	26.42	4.5/3.5	36.45	170.0	211.0	8.23
C24B-2	38.100	25.40	25.40	14.63	101.8	108.5	33.40	6.0/4.8	48.36	280.0	319.0	14.77
C28B-2	44.450	27.94	30.99	15.90	124.7	130.8	37.08	7.5/6.0	59.56	360.0	405.0	19.82
C32B-2	50.800	29.21	30.99	17.81	125.3	131.2	42.29	7.0/6.0	58.55	450.0	508.0	20.95
C08B-3	12.700	8.51	7.75	4.45	44.9	47.5	11.81	1.60	13.92	44.5	57.0	2.10
C10B-3	15.875	10.16	9.65	5.08	52.8	55.0	14.73	1.70	16.59	66.7	83.0	2.87
C12B-3	19.050	12.07	11.68	5.72	61.6	63.7	16.13	1.85	19.46	86.7	102.0	3.89
C16B-3	25.400	15.88	17.02	8.28	99.7	102.8	21.08	4.0/3.0	31.88	160.0	196.0	9.12
C20B-3	31.750	19.05	19.56	10.19	114.3	119.4	26.42	4.5/3.5	36.45	250.0	288.0	11.35
C24B-3	38.100	25.40	25.40	14.63	149.8	156.0	33.40	6.0/4.8	48.36	425.0	492.0	22.10
C28B-3	44.450	27.94	30.99	15.90	184.3	190.3	37.08	7.5/6.0	59.56	530.0	607.0	29.65
C32B-3	50.800	29.21	30.99	17.81	183.6	189.3	42.29	7.0/6.0	58.55	670.0	772.0	31.27

输送链  
Conveyor Chains

曳引链  
Leaf Chains

传动链  
Driving Chains

键槽和螺纹  
Keyway And Thread

A 系列滚子链轮  
Sprocket - A Series

B 系列滚子链轮  
Sprocket - B Series

双节距链轮  
Double Pitch Sprocket

双驱链轮  
Double Drive Sprocket

同步带轮  
Synchronous Pulley